



 **SIRENA 118**









118

LAYOUT OPTIONS  
**Standard Layout**

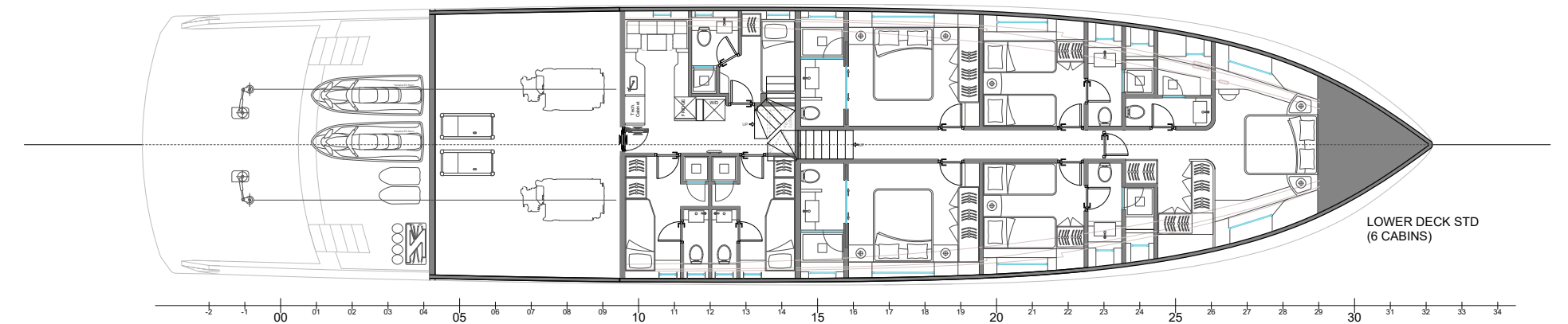
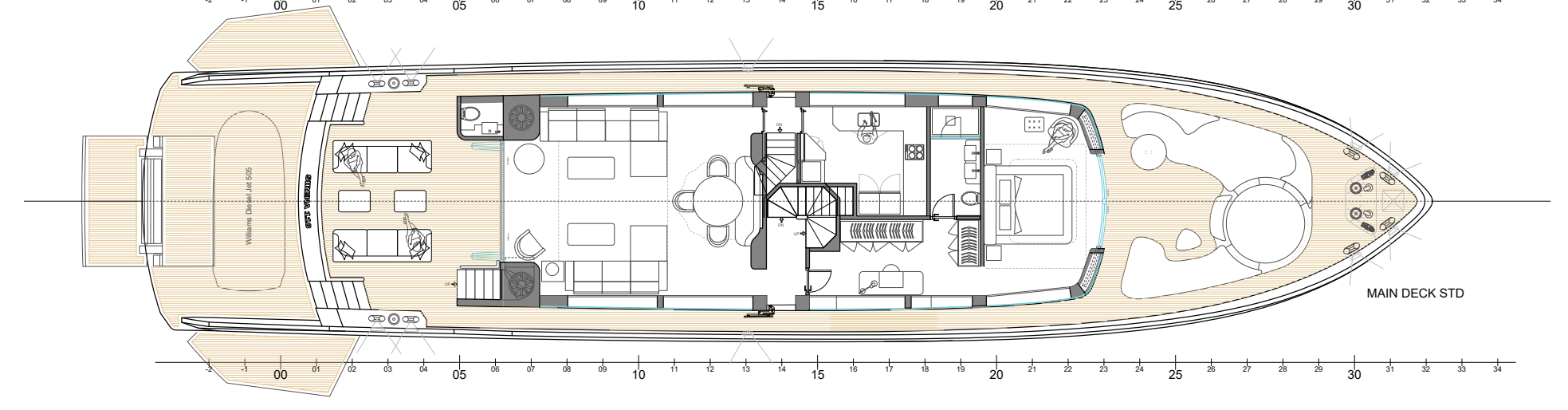
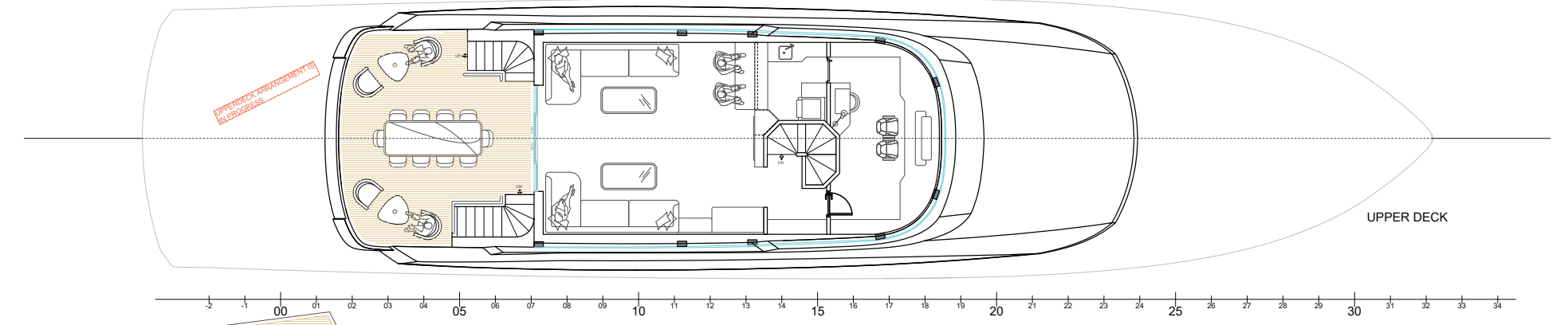
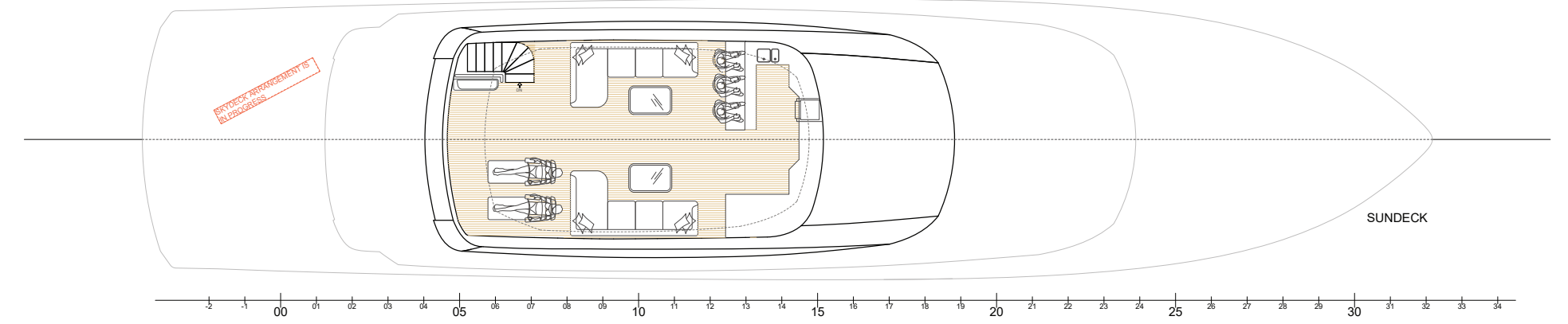
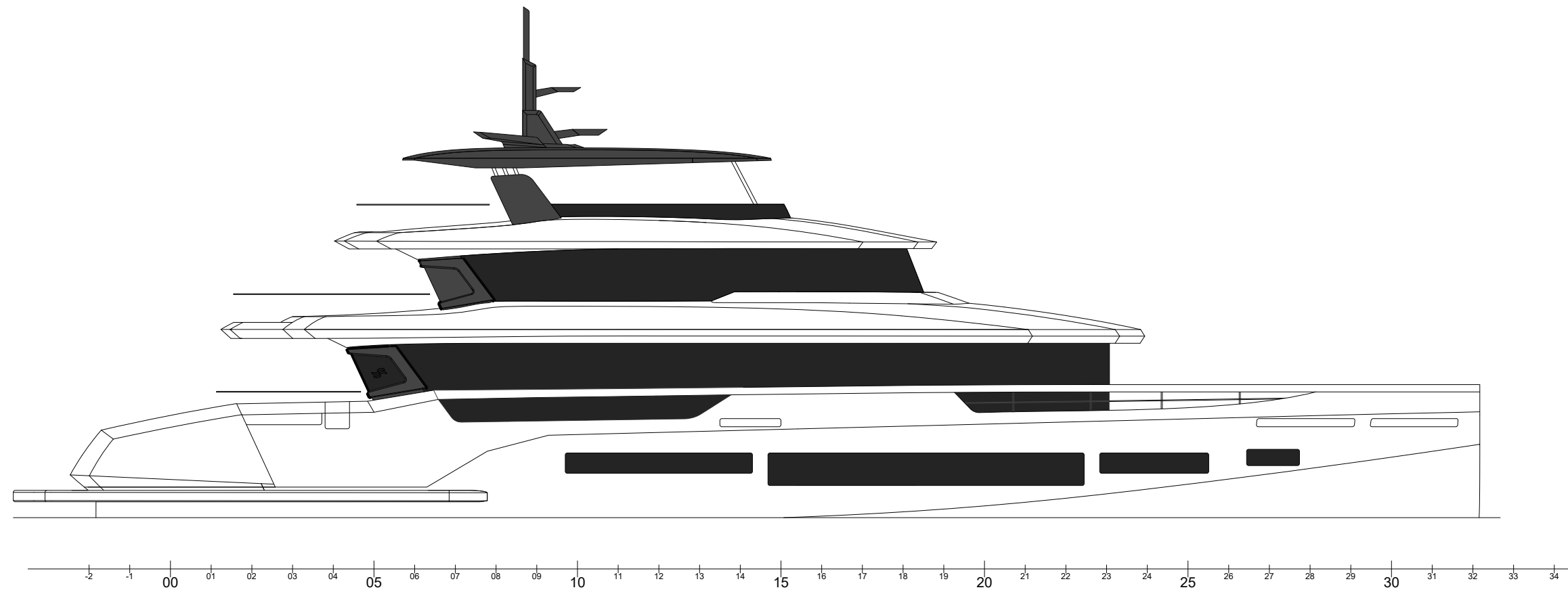

LAYOUT OPTIONS  
**Optional Layouts**

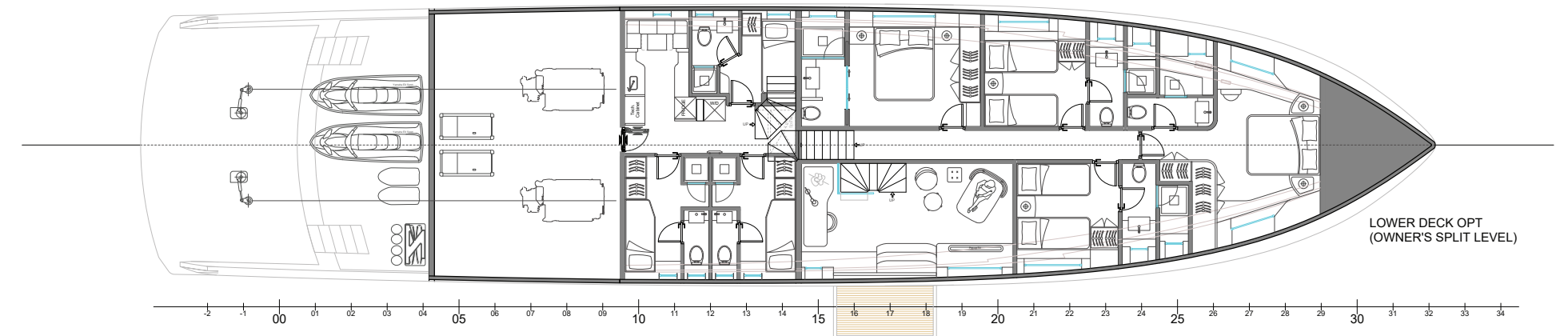
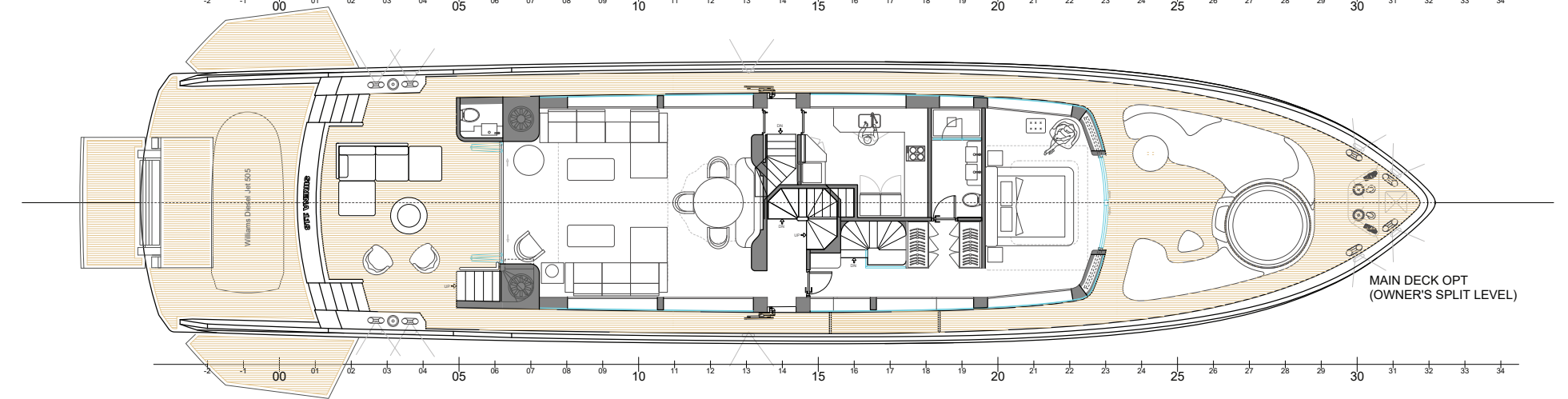
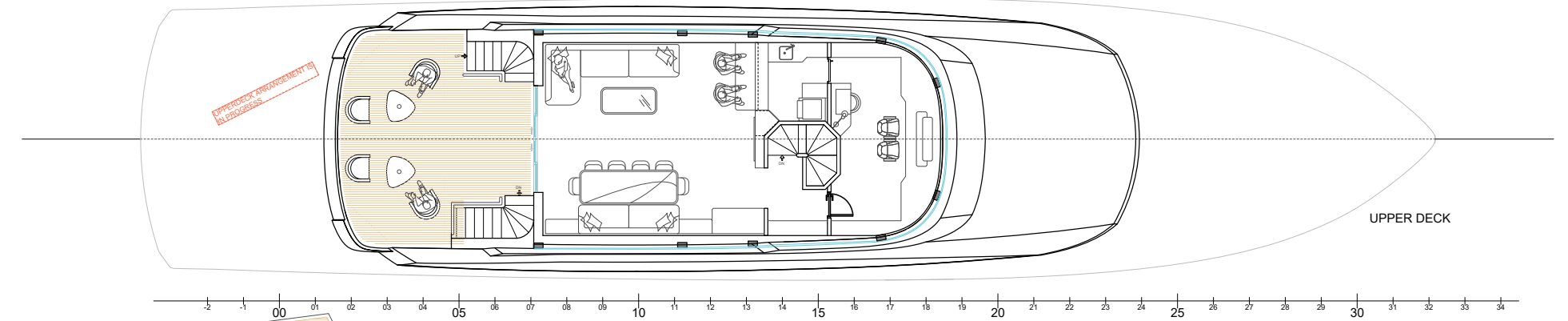
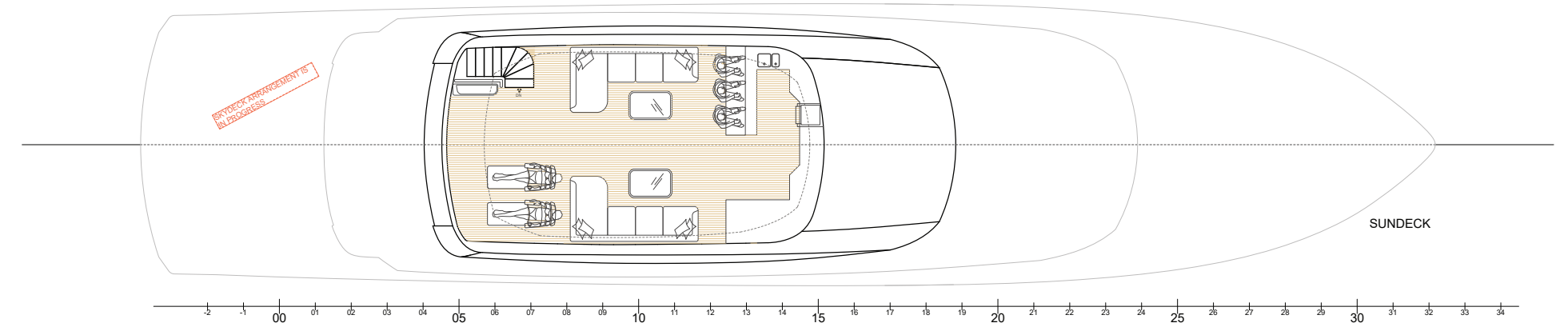
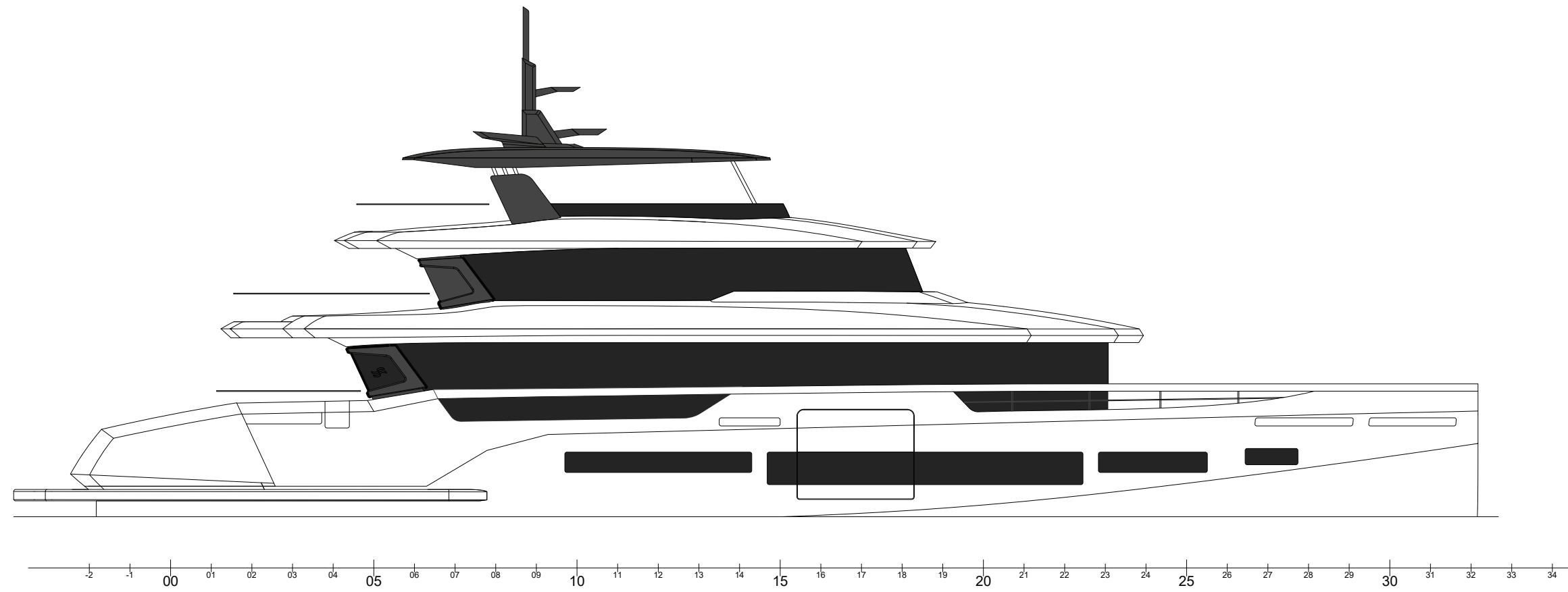

## DIMENSIONS AND MAIN CHARACTERISTICS

Length Overall L <sub>OA</sub>	36 m / 118'
Hull Length L <sub>H</sub> ISO 8666	34 m / 111'
Hull Beam BHmax ISO 8666	7,9 m / 25'
Gross tonnage (ITC '69)	265 GT
Cabins	5+1 cabins (12 people)
Heads	7
Crew	3 cabins (5 people)
Building materials	GRP
Hull Type	Fast Displacement
Exterior design	Sirena Design Team
Interior decor	Cor D Rover
Naval Architecture	German Frers
Engines	2 x 1550 HP MAN V12 2 x 1900 HP MAN V12
Cruising speed	15 knots
Max speed	18 knots 21 knots (with opt. engines)
Certification	RINA Pleasure Craft

\*NOTE: All performance specified in the table above are design data and applies to a standard configuration boat (standard equipment installed as per this standard list) with clean keel, propellers, and rudders. Furthermore, the performance levels indicated above have been defined under good sea and wind conditions (Beaufort Scale level 1, Douglas Scale level 1, ambient T < 25°, seawater T =15°, atmospheric P = 103250 Pa) with 2 people on board, 25% fuel, and fresh, grey and black water tanks empty. Different or harsher sea conditions and additional selected optional equipment may affect the performance.







**SIRENA YACHTS**

TR

Turkey, Headquarters

+90 212 219 74 74

Abdi İpekçi Cad. Ada Apt. No: 22/18  
K: 5 34367 Nişantaşı / İstanbul

[sales@sirenayachts.com](mailto:sales@sirenayachts.com)  
[www.sirenayachts.com](http://www.sirenayachts.com)

SIRENA MARINE